

DUAL FUEL CONVERSION FOR HIGH SPEED ENGINE

Huegli Tech LTD offers an innovative retrofit technology to convert your diesel engine systems to operate reliably and efficiently on Dual Fuel natural gas. We tailor each system to fit individual customer requirements.

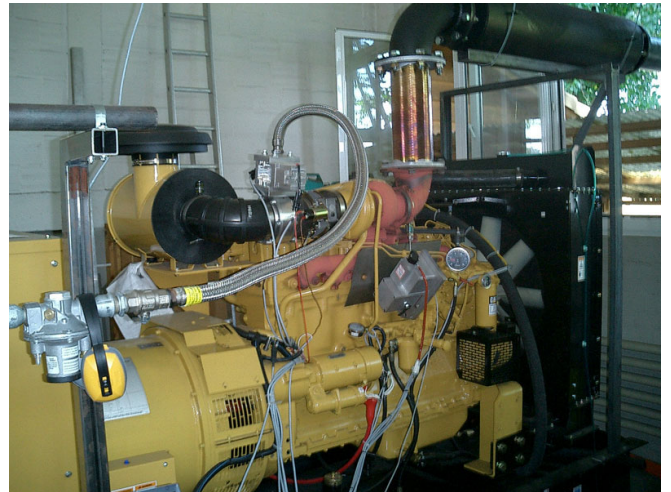

Return of Investment: Less than 6 Months

This kit is a relatively low cost way to get your existing high speed engine running on dual fuel. Taking advantage of inexpensive natural gas as a primary fuel, you will also retain the ability to run your engine on full diesel without losing horsepower. Current replacement rate of diesel-to-gas is approximately 70% of the diesel fuel.

Kit includes: Mixer system with integrated gas metering valve, electronic control system, gas delivery system, additional diesel delivery components, air controls, gas plumbing and necessary operational documentation

HIGHLIGHTS



- ☞ **Save Money with cheaper fuel**
- ☞ **Simple conversion is cost effective**
- ☞ **Low pressure Gas compatible**
- ☞ **100% power at diesel or dual fuel**

Block Diagram

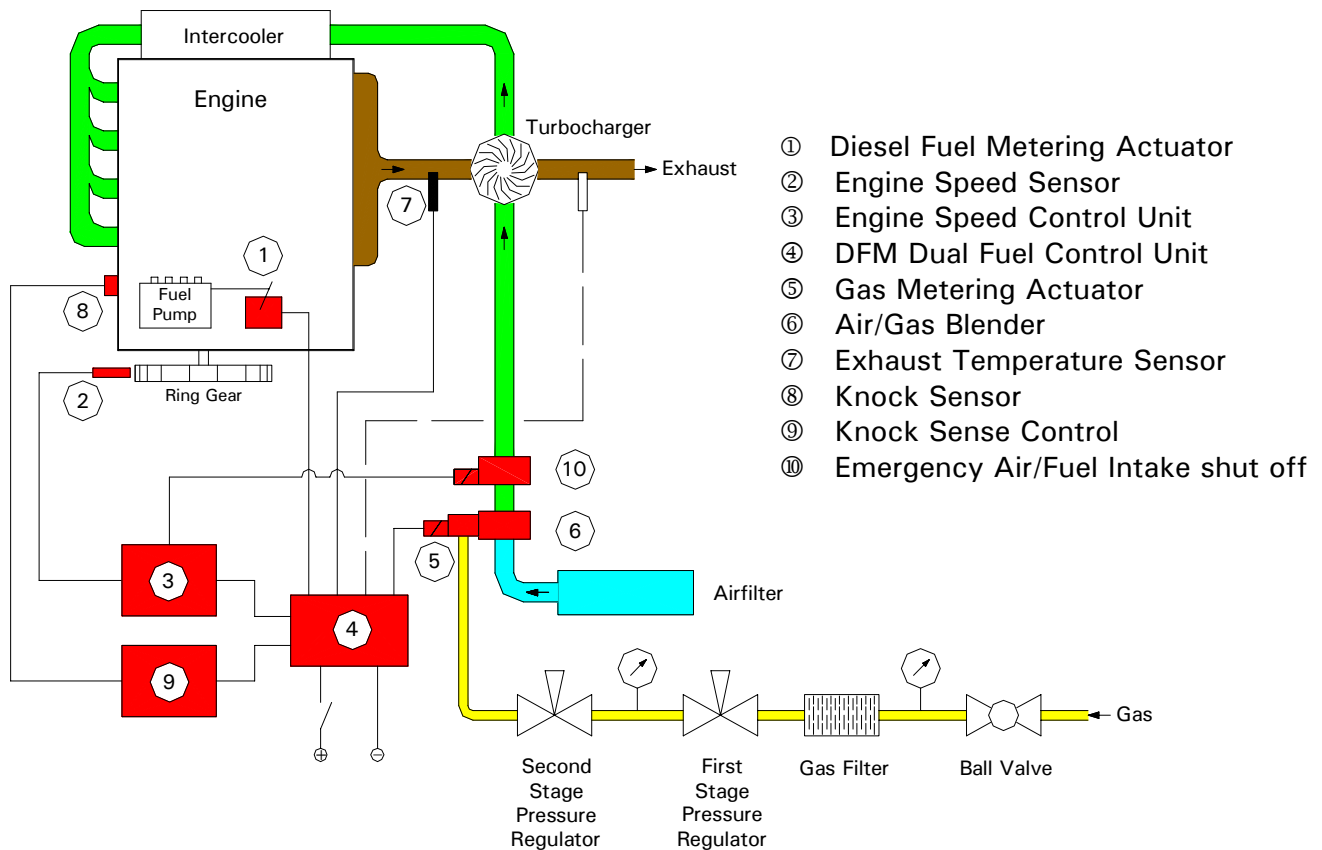

Target

The target is to **safely operate** the engine at a diesel fuel/gas ratio of 30/70, or even better, and maintain the **same power output**, and the same **fast response time** as with 100% diesel fuel.

Operating Principle

The DFM Dual Fuel Control ④ sets the amount of injected diesel fuel via the actuator with position sensor ①. The actuator is linked to the fuel pump. Via another actuator ⑤ the DFM control also regulates the amount of gas into the air/gas blender ⑥. The air/gas mixture then passes through the turbo charger, through the intercooler into the engine. The requested engine speed is controlled by the governor control ③, which measures the engine speed at the engine ring gear via speed sensor ②. Isochronous or droop mode is possible.

Dynamic Performance

The DFM has dynamic characteristics, i.e. during load steps it momentarily increases the amount of injected diesel fuel for shortest possible transients.

Protection and Safety

The system protects the engine against harmful situations.

The exhaust temperature is monitored via sensor ⑦. If the temperature should exceed the set (safe) Limit, the DFM control reduces the gas portion, and increases the diesel fuel portion.

The System also avoids harmful knocking. (Detonation)

One, or several knock sensors ⑧ signal any knocking tendency to the knock control ⑨, which then signals the DFM control ④ to change the gas/diesel fuel ratio to eliminate knocking.

Cost comparison

The comparison is based on Pakistan fuel and gas cost. An automatic calculation table is available in Excel which allows calculating with any fuel cost. Please contact us so we can provide more information to you.

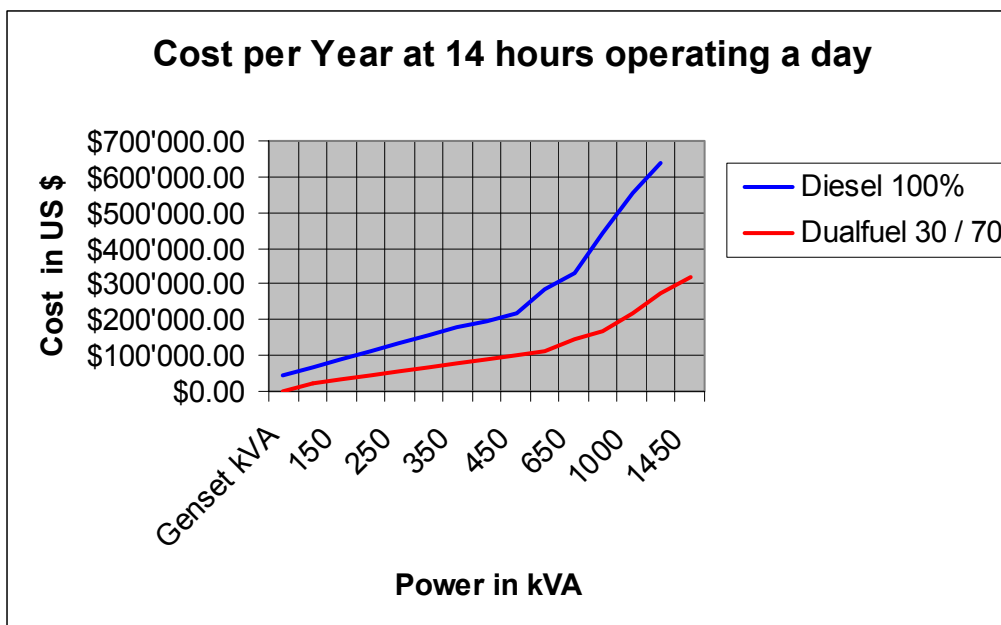
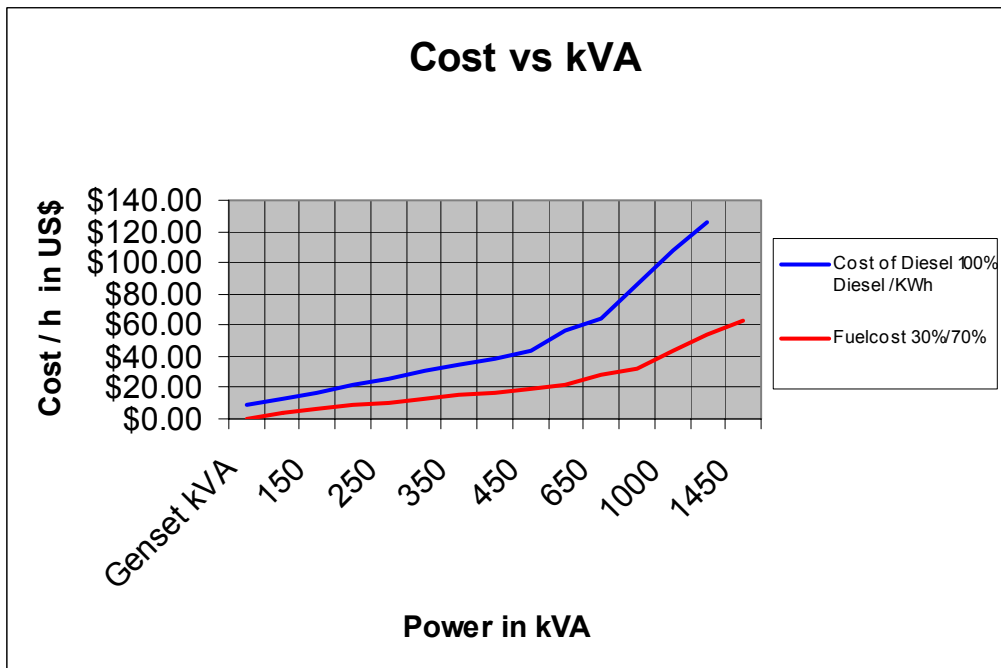

HUEGLI TECH LTD

Huegli Tech LTD introduces its latest dual fuel conversion system DFM 100, for the industrial high speed four stroke diesel engine market. The DFM 100, a cost effective and affordable means of converting diesel engines into diesel-natural gas engines, allowing the use of cost effective natural gas without changing the entire engine.

The DFM 100 dual fuel system is designed to be installed on new or existing diesel engines without modifying any internal engine components. Installations of the components are straightforward, with only reasonable mechanical expertise required. Final tuning and testing is typically performed by a trained service technician or a representative. Dual fuel units also allow the user the flexibility to run dual natural gas with diesel or strait diesel, an extremely important consideration for applications with interrupted gas supply. Diesel operation remains unchanged. The DFM 100 is engineered so if a function falls out of normal operational limits, full Diesel operation is resumed instantly and seamlessly, with no interruption of service.

How to do it

Installation of the kit usually takes a day or two. The kit is manufactured according to the dimensions given by the questionnaire returned to us and suits without additional modification. The site needs a gas supply line with at least 2 PSI of available gas pressure (higher pressures allows for smaller control devices and better stability of gas supply). Via Gas Street the supply is piped to the engine, close to the air inlet. The conversion system takes it from there to supply the diesel engine with a clean regulated gas supply that controls the fuel delivery to the engine and blends the fuel with the air. Sensors need to be fixed, to measure critical engine functions like speed, load, water temperature, exhaust temperature and gas pressure. Voltage for powering the control system is typically 24 volts DC. Mounting of the Diesel actuator to the fuel pump either integral or external solution without having special knowledge on fuel pumps. The gas actuator is already pre mounted to the Air / Gas Mixer. The mixer needs to be placed between the Air filter and Turbocharger. Wiring to connect the sensors to the Electronic Control Unit's.

To start up the first time, the DFM 100 can be adjusted in Diesel mode first, to avoid any engine damage.

! Easy, fast and qualified installation saves time and cost!

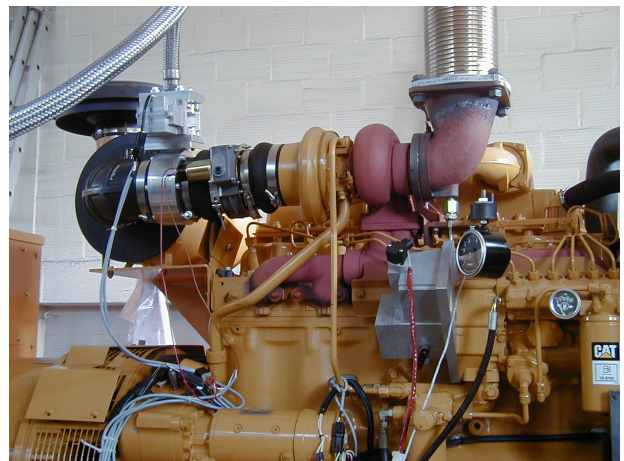



Quality

While reducing equipment cost is an important goal, no short cuts are taken with respect to quality. Only top quality products are utilized in the conversion system. From the Main Controller to the pick up connector, all meets high SWISS standard at an affordable price!

Fuel Economy

A DFM 100 conversion is a perfect investment for power users who are looking to upgrade their current system to alternative fuel technology, without revamping their entire system. As a retrofit technology, the DFM 100 system provides an economically attractive alternative instead of buying costly new generators.

With the ability to operate both fuels, the engine will never be down due to a lack of adequate gas fuel supply. Another distinct advantage of dual fuel is the decreased engine wear that comes with the use of cleaner fuel. Due to a reduction of carbon soot build-up and cleaner lube oil, longer intervals between service maintenance can be expected, sometimes doubled. This means a longer economic life for the engine and a better overall return on your investment.

Savings

To determine approximate cost savings you will need to be aware of your present fuel cost. The fuel replacement percentage and replacement cost with natural gas is in the ration of approx: 30 / 70, but also can be lower. Be sure to apply any losses of efficiency and always estimate on the safe side. Ask a

Huegli Tech representative to help you in determining your annual cost savings including fuel and maintenance.

When considering the cost of natural gas also consider your contract options with your gas supplier. Many suppliers are willing to give better rates if they are able to interrupt your fuel supply. An interruptible rate is exactly why the Dual Fuel system is a desirable option.

! Uninterrupted power supply around the clock saves cost for production and investment!



Safety Features

Combustion knock is where the air fuel mix in the combustion chamber starts to auto-ignite from the increasing pressures and high temperatures. It causes high pressure spikes and can cause engine damage. Knock is the reason many engines can not run full power at a minimized pilot fuel setting. Each engine family has its own differences and characteristics. Different fuel timing, compression ratio and Turbocharger configurations affecting air fuel ratio, boost pressures and temperatures. The ambient temperature affects the combustion and so does the content of the gas. All of these factors come into play and make it somewhat difficult to predict exactly what power limit will be reached with minimized pilot fuel and what amount of pilot fuel will be required at full power. The DFM 100 system is designed to replace as much diesel fuel as is possible without running into the combustion knock limit. To accomplish this, the controller has an additional input and communicates with a Ant knocking system which listens to the engine via high sensitive vibration piezo sensors. This allows reducing diesel as close to the knocking threshold as possible without endangering the engine at any time.

High exhaust temperature is monitored constantly via Thermocouple Sensor. An adjustable set point on the DFM 100 for high temperature will reduce the gas and increase diesel fuel to prevent the engine from damage. The DFM 100 will continuously govern along the knocking threshold if necessary. This feature helps to increase efficiency on CHP applications.

With an additional multifunctional genset controller, IntelliSys, each cylinder temperature can be monitored. IntelliSys is capable to reduce either the generator power or change the mode of the DFM 100 to single fuel operation.



Scope of Supply

Electronic's :

- **DFM-100 Dual Fuel Controller**
The DFM 100 is capable of controlling 2 actuators independently at the same time. It is possible to freeze one actuator to an adjustable value.
- **ESD-5330 Speed Governor High Performance**
The ESD 5330 is a speed governor with enhanced features which allows controlling any dynamic situation of a combustion engine.
- **IG-CU or IS-CU Genset Controller ***
IG-CU or IS-CU are enhanced gen-set automation controllers with engine protection features.
- **Denox-2DF Antiknocking Control ***
Denox detects the engine knocking via knocking sensors.

Actuators:

- **ACE-XXXF-24 Diesel Actuator**
To control the Diesel fuel proportionally either an integral type or external actuator is mounted to the fuel pump.
- **ATB-XXXF-24 Gas Valve Actuator**
This is an Integrated Butterfly actuator which controls the Gas fuel proportionally

Sensors:

- **MSP-6728C Magnetic Pick Up**
Magnetic Speed sensor to measure the engine speed.
- **Exhaust Temperature Sensor**
K-Type thermocouple to measure the exhaust temperature
- Knocking Sensor *

Air Gas MiXer:

- ! This device is selected according the questionnaire which has to be completed !

Gas Components:

- Gas Filter *
- Pressure Regulator *
- Manual Valves *
- Electric Valves *
- Pressure Switch *

*Indicates Optional Device.

Selection Table for various engines

Engine	Remarks	Diesel Actuator	Gas Actuator	Speed Pick Up
Cummins				
NT 855	PT Pump System	ADB 120 E4 HTF	ATB 350F-24	MSP 6728C
NTA 855	PT Pump System	ADB 120 E4 HTF	ATB 350F-24	MSP 6728C
KT/KTA Series	PT Pump System	ADB 120 E4 HTF	ATB 450F-24	MSP 6728C
Caterpillar				
3306		ACD 295F-24	ATB 350F-24	MSP 6728C
3512		ACB 2001F	ATB 550F-24	MSP 6728C
3516		ACB 2001F	ATB 550F-24	MSP 6728C
Deutz				
913		ACD 175 F-24	ATB 350F-24	MSP 6728C
1015		ACE 275 F-24	ATB 350F-24	MSP 6728C
1012/13		ADD 180GF-24	ATB 350F-24	MSP 6728C
MAN				
2842		ACE-275F-24	ATB 350F-24	MSP 6728C
2866		ACE-275F-24	ATB-350F-24	MSP6728C
Dewoo				
TD 229		ACD 175 F-24	ATB 350F-24	MSP 6728C

Selection Table for Perkins engines

Engine	Diesel Actuator	Gas Actuator	Mounting Kit	Pick-up
1306 (TAG)	ACD -175F-24	ATB 350F- 24	KT 275-3000	MSP 6728C
2006 (TA)	ACE 275F-24	ATB 350F -24	KT 275-3000	MSP 6728C
3008 (TA)	ACE 275F-24	ATB 450F -24	KT 275-3000	MSP 6728C
3012 (TWA)	ADD 225F or ACE 275F	ATB 450F -24	KT 225/3012C (M10) or KT225/3012D (M8) Kit on request	MSP 6728C
4000...TAG Dorman range)	ACB 2001F	ATB 550F -24	Kit on request	MSP 6728C



Selection Table for Volvo engines

Engine	Bosch fuel pump	Diesel Actuator	Gas Actuator	Mounting Kit
TD 420, TAD 420	Stack Pump's	ADD 225F-S-24 ADD 180GF-24	ATB 350F-24	CH 1208AM-L3 KT 1213 B CH 1220-L3
TD 520, TAD 520			ATB 350F-24	
TD 720, TAD 720			ATB 350F-24	
TD 610, TWD 610	MW	ACD 175F-24	ATB 350F-24	KT-166
TD 710, TWD 710	if P 3000	ACD 175F-24	ATB 350F-24	KT 275-3000
	if P 7000	ACD 175F-24	ATB 350F-24	KT 276-7000
TAD 721 TAD 730 TAD 740 TAD 741	if P 3000	ACD 175F-24	ATB 350F-24 ATB 350F-24	KT 275-3000
	if P 7000	ACD 175F-24	ATB 350F-24 ATB 350F-24	KT 276-7000
TD 1010	if P 3000	ACD 175F-24	ATB 350F-24	KT 275-3000
	if P 7000			KT 276-7000
TAD 1030 TAD 1031 TAD 1032	P 7000	ACD 175F-24	ATB 450F-24	KT 276-7000
TWD 1211 TAD 1231	if P 3000	ACD 175F-24	ATB 450F-24	KT 275-3000
	if P 7000	ACD 175F-24		KT 276-7000
TAD 1230	P 7000	ACD 175F-24	ATB 450F-24	KT 276-7000
TAD 1232 TAD 1240 TAD 1241 TAD 1242	Up on request			
TAD 1630	P 7000	ACE 275F-24	ATB 550F-24	KT 276-7000
TAD 1631 TAD 1632 TAD 1633	RP 21	ACE 275F-24	ATB 550F-24	KT 1611

