

Braking Systems in Railway Vehicles

Rakesh Chandmal Sharma¹, Manish Dhingra²,
Rajeev Kumar Pathak³

¹Department of Mechanical Engineering, M. M. University, Mullana (Ambala) INDIA,

²Department of Mechanical Engineering, T. M. University, Moradabad INDIA

³Department of Mechanical Engg, Rakshpal Bahahur College of Engg. and Tech., Bareilly INDIA

Abstract— Brake is an essential feature in order to retard and stop the railway vehicle within minimum possible time. This paper presents a discussion about the different braking systems used in railway vehicles. This paper also considers electrodynamic and electromagnetic braking of trains, which is of particular importance in high-speed trains. The calculation for stopping distance for railway vehicle is provided in this study.

Keywords— Air brake; Straight air brake system; Automatic air brake system; Braking distance; Brake cylinder; Brake pipe; Vacuum brake; Brake delay time

I. INTRODUCTION

The brakes are used on the coaches of railway trains to enable deceleration, control acceleration (downhill) or to keep them standing when parked. While the basic principle is similar from road vehicle, the usage and operational features are more complex because of the need to control multiple linked carriages and to be effective on vehicles left without a prime mover. In the control of any braking system the important factors that govern braking action in any vehicle are pressure, surface area in contact, amount of heat generation and braking material used. Keeping in view the safety of human life and physical resources the basic requirements of brake are:

- The brake must be strong enough to stop the vehicle during an emergency with in shortest possible distance.
- There should be no skidding during brake application and driver must have proper control over the vehicle during emergency.
- Effectiveness of brakes should remain constant even on prolonged application or during descending on a down gradient
- Brake must keep the vehicle in a stationary position even when the driver is not present.

The brake used in railway vehicles can be classified according to the method of their activation into following categories.

- Pneumatic Brake
- Electrodynamic Brake
- Mechanical Brake
- Electromagnetic Brake

Pneumatic Brake may be further classified into two types

- Vacuum Brake
- Compressed air brake

Researchers in the past have investigated different aspects of braking of railway vehicle. Bureika & Mikaliunas [1] provided the calculations for Vehicle Braking Force Fitted with UIC Air Brake for Passenger Trains, Wagon Braking Force Fitted with a UIC Air Brake for Freight Trains Wagon, Braking Distance. Liudvinavicius & Lingaitis [2] studied different features and related mathematics of electrodynamic braking in high-speed trains. Vernersson [3] developed a dimensional finite element model of block and wheel, which was coupled through a contact interface for the purpose of control of heat generation and also the heat partitioning at block-wheel surface through thermal contact resistances. Influence of temperature in wheels and brake block at rail tread braking was analyzed under brake rig conditions in the later part of study by Vernersson [4]. Teimourimanesh et al. [5, 6] also investigated the influence of temperature on railway tread braking in their study. Author in the past evaluated the different performance indices of railway vehicles [7, 8, 9, 10, 11 and 12], Author also carried out a broad study of magnetically levitated [13] and air cushion [14] vehicles in the recent past, presenting a summary of different types of brakes used in railway vehicles in this paper.

II. VACUUM BRAKE & ITS LIMITATIONS

The vacuum brake system derives its brake force from the atmospheric pressure acting on the lower side of the piston in the vacuum brake cylinder while a vacuum is maintained above the piston. The train pipe runs throughout the length of the coach and connected with consecutive coaches by hose coupling. The vacuum is created in the train pipe and the vacuum cylinder by the ejector or exhauster mounted on the locomotive.

Vacuum brake system has following limitations:

- Brake cylinder piston takes longer time to release after each application of brakes because of single train pipe. On a very long train, a considerable volume of air has to be admitted to the train pipe to make a full brake application, and a considerable volume has to be exhausted to release the brake.
- Vacuum brakes are not suitable for high speed trains the maximum pressure available for brake application is only atmospheric. The brake power is inadequate for higher loads and speed.
- The practical limit on the degree of vacuum attainable means that a very large brake piston and cylinder are required to generate the force necessary on the brake blocks.

The existence of vacuum in the train pipe can cause debris to be sucked in.

III. AIR BRAKE SYSTEMS

A. Automatic Air Brake System

An automatic air brake system is shown in Fig. 1. Air compressors mounted every two to four coaches supply compressed air to the air brakes. The air, which is compressed

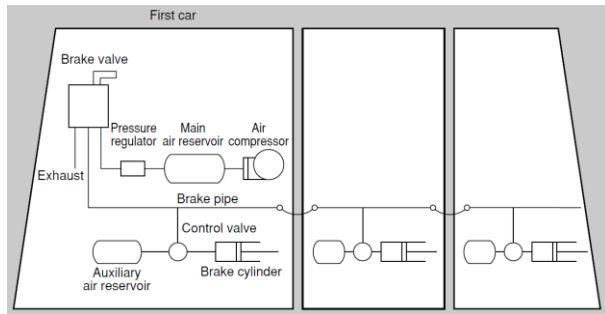

Fig. 1. Principle of automatic air brake system

to nearly 8 kg/sq cm, is piped below coach floors to main air reservoirs. The air pressure is lowered to 5 kg/sq cm with pressure regulator and air is fed via the brake valve, brake pipes, and control valves to auxiliary air reservoirs. If the compressed air in the brake pipes and auxiliary air reservoirs of each coach is at 5 kg/sq cm, brakes are not activated. The activated brake valve cuts the flow of air from the pressure regulator and air pressure in the brake pipes falls. The fall in air pressure is detected by the control valves on each coach. The control valves then regulate the flow of compressed air from auxiliary air reservoirs to brake cylinders. The brake cylinders activate the basic braking mechanisms to slow down and stop the coach. The control valves regulate the flow of air from the auxiliary air reservoirs to the brake cylinders at a pressure that is proportional to pressure drop in the brake pipes.

B. Straight Air Brake System

A straight air brake system is shown in Fig. 2. The straight air brake system does not have a control valve or auxiliary air reservoir in each coach as in automatic air brake system. Activation of brake valve forces compressed air from straight air pipe to brake cylinders, activating the basic braking mechanism. As the straight air pipes do not contain compressed air during normal running conditions, the brakes would fail if coaches became uncoupled. In order to avoid this, the straight air brake system may be used in conjunction with the automatic air brake system. It can also be avoided by using another pipe, called a main air reservoir pipe, from the first to the last coach. The air pressure in main air reservoir pipe acts like the compressed air in the brake pipes of the automatic air brake system. If compressed air in this main air reservoir pipe falls, or if it leaks from air pipes or from air hoses between coaches, etc., pressure drop is detected and brakes are applied automatically.

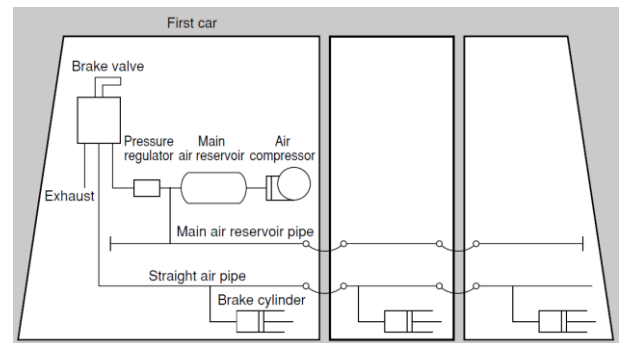

Fig. 2. Principle of straight air brake system

Air brake system may also be classified as follows:

- Direct release air brake system
- Graduated release air brake system

Direct release air brake system is most suitable for leveled track or constant gradient route. Due to this reason it is not suitable for Indian Railways. Graduated release air brake system is most suitable for Indian Railways. In graduated release air brake system the brake pressure is applied and released such that the magnitude of braking force is proportional to reduction in brake pipe pressure.

Graduated release air brake system can also be divided into two categories.

- Single pipe graduated release air brake system
- Twin pipe graduated release air brake system

C. Single Pipe Graduated Release Air Brake System

Single Pipe Graduated Release Air Brake System is shown in Fig. 3. The operation is same as that of the twin pipe system except that the auxiliary reservoir is charged through the D.V. instead of feed pipe, since there is no feed pipe in single pipe system. As compared to single pipe graduated release air brake system, twin pipe graduated release air brake system is more suitable for passenger coaches.

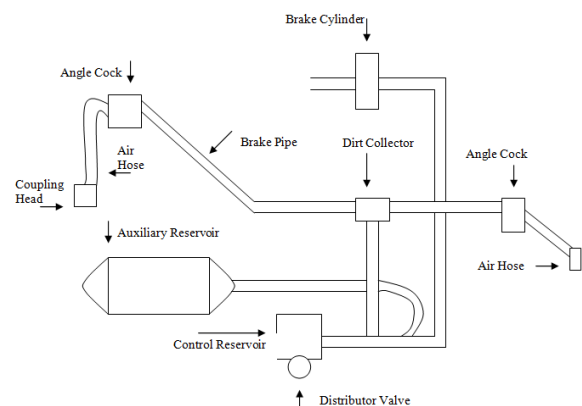

Fig. 3. Single pipe graduated release air brake system

D. Twin Pipe Graduated Release Air Brake System

In twin pipe graduated release air brake system (Fig. 4), The Brake pipe is charged to 5 kg/cm² by the driver's brake valve. The auxiliary reservoir is charged by the feed pipe at 6 kg/cm² through check valve and choke. The brake cylinder is connected to the atmosphere through a hole in the D.V. when brakes are under fully released condition. To apply brakes, the driver moves automatic brake valve handle

either in steps for a graduated application or in one stroke to the extreme position for emergency application. By this movement the brake pipe pressure is reduced and the pressure differenced is sensed by the D.V. against the reference pressure locked in the control reservoir. Air from the auxiliary reservoir enters the brake cylinder and the brakes are applied. At the time of release the air in the brake cylinder is vented progressively depending upon the increase in the brake pipe pressure. When the brake pipe pressure reaches 4.8 kg/cm^2 the brake cylinder is completely exhausted and brakes are fully released.

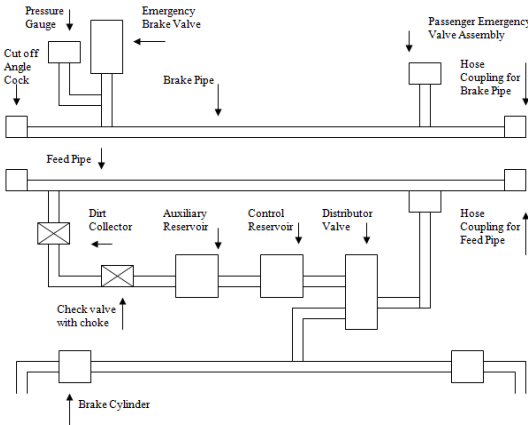

Fig. 4. Twin pipe graduated release air brake system

E. Advantages of Air Brake over Vacuum Brake

The air brake is preferred in rail vehicles over vacuum brake due to the reasons listed in Table 1.

TABLE I. ADVANTAGE OF AIR BRAKE OVER VACUUM BRAKE

S.N.	Parameters	Air Brakes	Vacuum Brakes
1.	Emergency braking distance (level track, 65 km/hr speed)	632 m	1097 m
2.	Brake power fading	No fading	At least by 20%
3.	Weight of Equipments per wagon	275 kg (Approx)	700 kg (Approx)
4.	Pressure Gradient	No appreciable difference in air pressure between locomotive and brake van upto 2000 m.	Steep reduction in vacuum in trains longer than 600 m.
5.	Preparation time in yards	Less than 40 minutes	Upto 4 Hrs
6.	Safety on down gradients	Very safe	Need additional precautions
7.	Overall reliability	Very good	Satisfactory

IV. ELECTRODYNAMIC BRAKING SYSTEM

Braking system used in electric trains is electrodynamic braking that converts the motor into a braking generator dissipating the kinetic energy in the form of heat. Regenerative braking uses the generated electricity instead of dissipating it as heat, and is becoming more common due to its ability to save energy. Principle of the electrodynamic traction, dynamic braking and regenerative braking systems is shown in Fig. 5, 6 and 7 respectively.

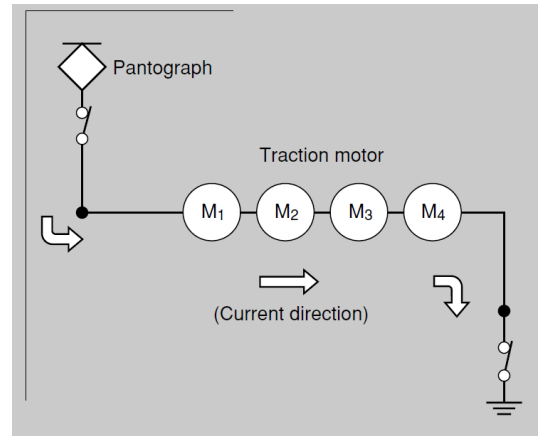

Fig. 5. Principle of electrodynamic traction

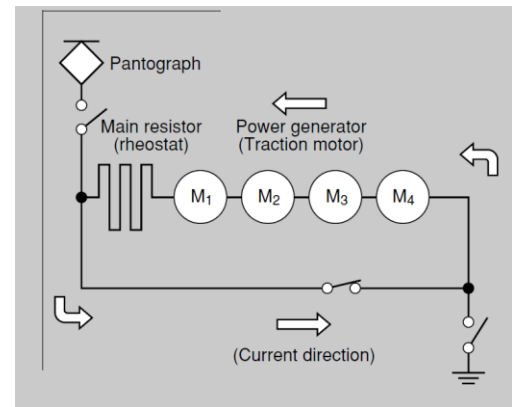

Fig. 6. Principle of dynamic braking

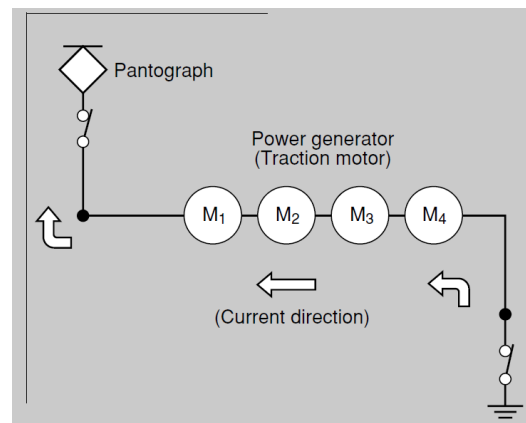

Fig. 7. Principle of regenerative braking

V. MECHANICAL BRAKING SYSTEM

The basic braking devices used by mechanical braking systems are: wheel tread brakes (Fig. 10), axle-mounted disc brakes (Fig. 11), and wheel-mounted disc brakes (Fig. 12). These brake mechanisms use a brake shoe that applies friction force to the disc. The applied pressure is adjusted to control the braking force. In wheel-tread brake, the brake shoe applies friction force to the wheel tread, creating a sliding effect. High-speed trains cannot use this type of brake, because doing so may damage the wheel tread. Therefore, they use axle- or wheel-mounted disc brakes. Axle-mounted disc brakes require sufficient space to accommodate therefore used in trailer bogies. Wheel-mounted disc brakes are used on motor bogies because it requires accommodating the traction motor only and having insufficient space for an axle-mounted brake. In both systems, compressed air or oil is applied to a brake cylinder that pushes the brake lining against the disc. Brake discs are dead weight that is useful only during braking, therefore operators can install lighter discs. Carbon/carbon-composite multi-discs and aluminium composite discs offer lighter weights and are widely used. The carbon/carbon-composite multi-disc has alternate sections of carbon-fiber rotors and stators. During braking, they rub against each other to create a frictional force that slows down the wheel or axle. The disc is lighter in weight than conventional materials and has good heat-resistant properties. (Fig. 13) Aluminium-composite brake discs may be made much lighter than today's forged steel and cast-iron brake discs. Moreover their structure is common for both axle- or wheel-mounted discs, achieving a much lighter disc without design.

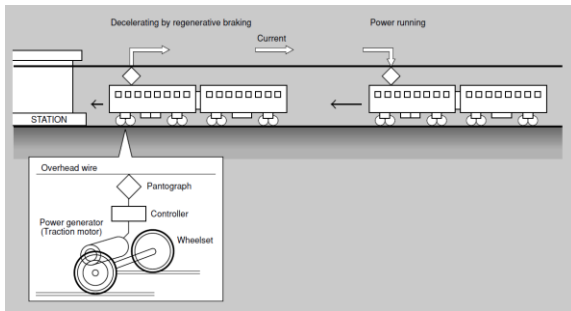

Fig. 8. Principle of recycled regenerated electric power

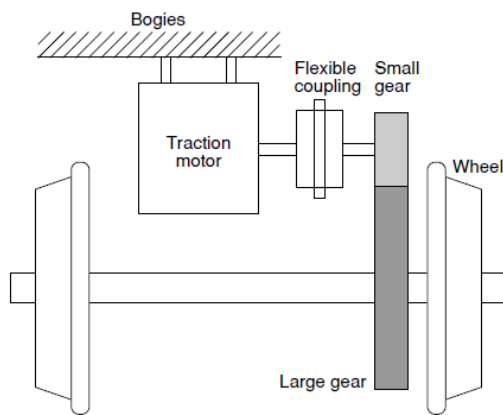

Fig. 9. Transmission of braking force from traction motors to wheels

The traction motor drives and accelerates the train, during braking and it acts as an electric generator instead, forming part of a circuit that consists of a rheostat, armatures and a field system. Electricity is consumed by the main resistor, which converts kinetic energy of the train into heat and acts as a brake. Regenerative braking uses the same type of circuit; however the electricity generated by braking is not consumed by rheostat. It is transmitted to the overhead wire. The flow of this electricity is controlled by a controller under the pantograph that opens and closes within fraction of time. Electrodynamic brake systems are economical to use because they do not have friction elements, as in mechanical brake systems. The regenerative braking system is even more economical because the electricity regenerated from the train's kinetic energy is transmitted to the overhead wire, and becomes available to power other rolling stock (Fig. 8)

However electrodynamic brake systems occasionally malfunction because they have complex circuits. Therefore they cannot be used as emergency brakes. In an electrodynamic braking system, the braking force of the traction motor is transmitted to the wheels via gears (Fig. 9).

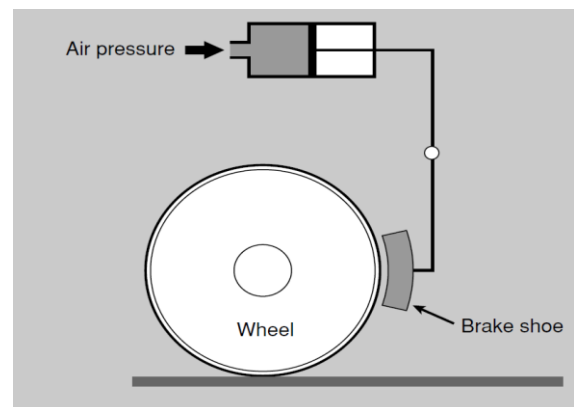

Fig. 10. Principle of wheel tread brakes

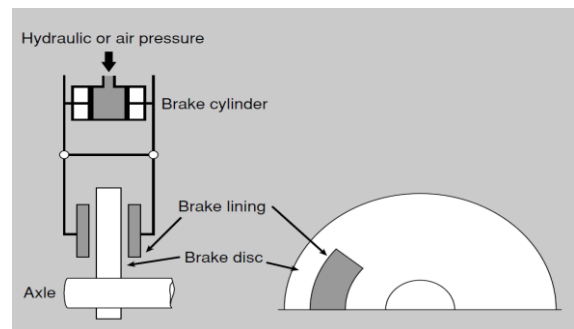

Fig. 11. Principle of axle-mounted disc brakes

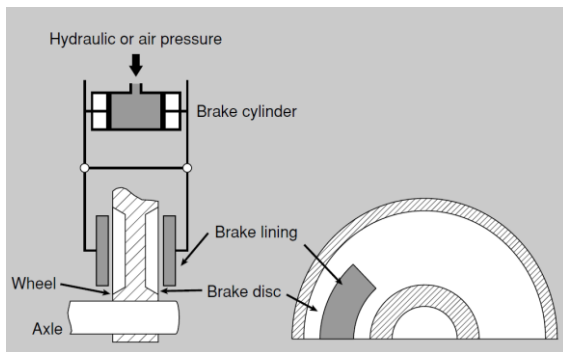

Fig. 12. Principle of wheel-mounted disc brakes

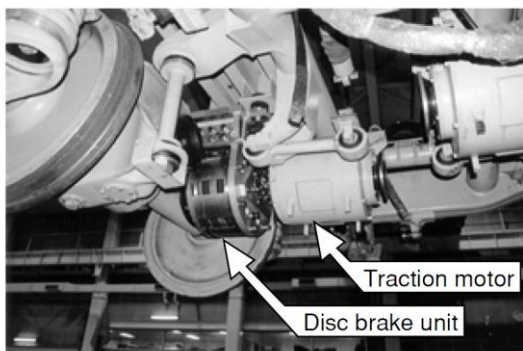

Fig. 13. Carbon/Carbon-composite multi-disc system

VI. ELECTROMAGNETIC BRAKING SYSTEM

Conventional train braking systems depend heavily on adhesion between the wheel tread and the rail. In the case high-speed trains, adhesion decreases as speeds increase, making it necessary for the train to reduce braking force to avoid wheel sliding. This result is longer braking distances. To overcome this problem, a electromagnetic brake system that does not depend on adhesion was developed. It produce a braking force by using magnetic repulsion obtained from eddy currents generated on the top surface of the rails. Earlier it was not used because of assumption that the eddy currents would heat small sections of the rail to such a degree that the rail would bend sideways. This is solved by development of a electromagnetic brake that uses eddy currents and frictional force. Fig. 14 shows the principle of electromagnetic brake. The electromagnetic brake on bogie is connected to batteries that create alternating north and south poles forming magnetic fields between the poles. The magnetic fields generate eddy currents in the top surface of the rails, creating a force acting in an opposite direction to the movement of the train, in other words, a braking force. An on field view of electromagnetic brake is shown in Fig. 15.

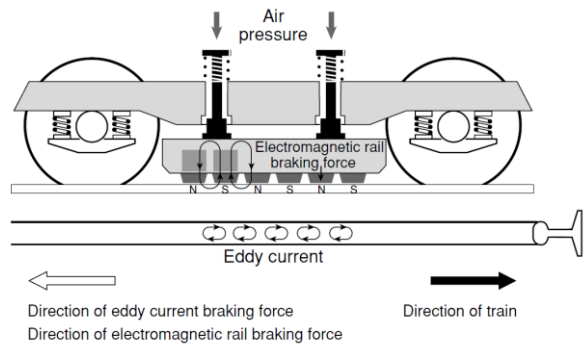

Fig. 14. Principle of electromagnetic brake

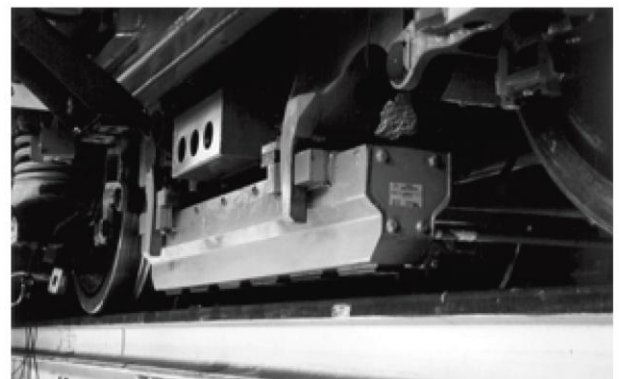

Fig. 15. An on field view of electromagnetic brake

VII. CALCULATION OF TRAIN STOPPING DISTANCE

For trains to safely travel on a railway, trains must be provided with sufficient distance in which to stop. Allowing too long a distance reduces the capacity of the line and has an impact on rail infrastructure investment. Too short a distance and collisions would occur, because the train would not be able to stop within the available distance and would therefore occupy a section of track that could be allocated to another train. Consequently it is important that distance be adequate. Train breaking distance is function of following factors

- Train speed when the brakes are applied.
- The available friction at wheel-rail surface which influences the retardation rate for complete brake application.
- Time from when the brakes are applied by the train driver to when they are actually become effective i.e. brake delay time.
- The magnitude of wear of brake pads and the pressure available in brake cylinders.
- Track gradient when brakes are applied and mass distribution of track.

In order to stop the train it requires the work. The required work is the sum of change in the train's kinetic energy and the change in its potential energy due to change in the height due to the gradient of the track.

Mathematically it may be expressed as:

$$maS + \frac{mV^2}{2} + mg(h_2 - h_1) = 0 \quad (1)$$

where

m = mass of train, V = Speed at which the retardation begins

S = Stopping distance, h_1 = Height at which the retardation begins,

h_2 = Height at which the train stops ($h_2 \geq h_1$)

a = Retardation provided by braking system,

The above equation suggests that mass has no direct effect on the train stopping distance. However mass distribution has influence on train stopping distance as train's centre of gravity varies with the mass distribution. In case of freight wagons where the mass varies from no load to full load there are two levels of brake force used 'empty' and 'loaded'. This influences the design of the brake system. For calculating the braking distance calculations the lowest deceleration rate is used to calculate the deceleration rate for the complete train.

Eq. 1 may be written as

$$S = \frac{(-V^2)}{2(a - g \tan \alpha)}, \text{ for } a < 0 \quad (2)$$

α = Angle of slope, for small values of α , $\sin \alpha \approx \tan \alpha$

Assuming constant gradient track and considering brake delay time the stopping distance can be calculated using following expression

$$S = \frac{(-V + bt_d)^2}{2(a + b)} - Vt_d - \frac{bt_d^2}{2} \quad (3)$$

b = Retardation provided by gravity

t_d = Brake delay time

VIII. CONCLUSIONS

- Vacuum brakes have extremely limited applications because of longer longer to function and unsuitable for high speed trains.
- Air brakes are efficient as compared to vacuum brakes; however they require considerable stopping distance therefore cannot be used for emergency braking.
- Mechanical brakes should be kept in reserve in parallel with another breaking technique and should be used to completely stop the engine at low speed.
- The required braking forces can be obtained in a wide range, with regeneration braking used in a high-speed range and rheostat braking in low speed range.
- Electrodynamic brake systems occasionally malfunction because they have complex circuits. Therefore they cannot be used as emergency brakes.
- Electromagnetic braking in high-speed train is efficient method of breaking.

REFERENCES

[1] G. Bureika & S. Mikaliunas, "Research on the compatibility of the calculation methods of rolling-stock brakes", *Transport*, vol. 23, issue 4, 2008, pp. 351-355.

[2] L. Liudvinavicius & L. P. Lingaitis, "Electrodynamic braking in high-speed rail transport", *Transport*, vol. 22, issue 3, 2007, pp. 178-186.

[3] T. Vernersson, "Temperatures at railway tread braking. Part 1: Modeling", *Proceedings of the Institution of Mechanical Engineers*,

Part F: Journal of Rail and Rapid Transit, vol. 221, issue 2, 2007, pp. 167-182.

- [4] T. Vernersson, "Temperatures at railway tread braking. Part 2: Calibration and numerical examples", *Proceedings of the Institution of Mechanical Engineers, Part F: Journal of Rail and Rapid Transit*, vol. 221, issue 4, 2007, pp. 429-441.
- [5] S. Teimourimaneh, T. Vernersson, R. Lunden, F. Blennow, M. Meinel, "Tread braking of railway wheels - temperatures generated by a metro train", *Proceedings of the Institution of Mechanical Engineers, Part F: Journal of Rail and Rapid Transit*, vol. 228, issue 2, 2014, pp. 210-221.
- [6] S. Teimourimaneh, T. Vernersson, R. Lunden, "Modelling of temperatures during railway tread braking: Influence of contact conditions and rail cooling effect", *Proceedings of the Institution of Mechanical Engineers, Part F: Journal of Rail and Rapid Transit*, vol. 228, issue 1, 2014, pp. 93-109.
- [7] R.C. Sharma, "Recent advances in railway vehicle dynamics", *Int. J. Vehicle Structures & Systems*, vol. 4, issue 2, 2012, pp. 52-63.
- [8] R.C. Sharma, "Ride analysis of an Indian railway coach using Lagrangian dynamics", *Int. J. Vehicle Structures & Systems*, vol. 3, issue 4, 2011, pp. 219-224.
- [9] R.C. Sharma, "Modeling and simulations of railway vehicle system", *International Journal of Mechanical Engineering and Robotics Research*, vol. 1, issue 1, 2014, pp. 55-66.
- [10] R.C. Sharma, "Sensitivity Analysis of ride behaviour of Indian railway Rajdhani coach using Lagrangian Dynamics", *Int. J. Vehicle Structures & Systems*, vol. 5, issue 3-4, 2013, pp. 84-89.
- [11] R.C. Sharma, "Parametric analysis of rail vehicle parameters influencing ride behavior", *International Journal of Engineering Science and Technology*, vol. 3, no. 8, 2011, pp. 54-65.
- [12] R.C. Sharma, "Stability and eigenvalue analysis of an Indian railway general sleeper coach using Lagrangian dynamics", *Int. J. Vehicle Structures & Systems*, vol. 5, issue 1, 2013, pp. 9-14.
- [13] R.C. Sharma, M. Dhingra, R.K. Pathak, M. Kumar, "Magnetically Levitated Vehicles: Suspension, propulsion and guidance", *International Journal of Engineering Research & Technology*, vol. 3, issue 11, 2014, pp. 5-8.
- [14] R.C. Sharma, M. Dhingra, R.K. Pathak, M. Kumar, "Air cushion vehicles: Configuration, resistance and control", *Journal of Science*, vol. 4, issue 11, 2014, pp. 667-673.
- [15] R. Kumar, M.P. Garg and R.C. Sharma, "Vibration analysis of radial drilling machine structure using finite element method", *Advanced Materials Research*, vol. 472-475, 2012, pp. 2717-2721.
- [16] A.Vashist, R.C. Sharma, S. Taneja, "Productivity improvement by defect analysis in indian automobile industry", *International Journal of Mechanical Engineering Research and Development*, vol. 2, issue 2, 2012, pp. 734-741.
- [17] A.Vashist, R.C. Sharma, S. Taneja, "Productivity improvement by fixture modification", *International Journal of Mechanical Engineering Research and Development*, vol. 4, issue 3, 2014, pp. 54-62.
- [18] V. Singla, R.C. Sharma, J. Singh, "Fault diagnosis of bearing for wear at inner race using acoustic signal", *International Journal of Mechanical Engineering Research and Development*, vol. 1, no. 1, 2011, pp. 40-46.
- [19] A.H. Wickens, "Fundamentals of rail vehicle dynamics", Swets & Zeitlinger publishers, Netherlands, 2003.
- [20] Z. Zhang and M. Dhanasekar, "Dynamics of railway wagons subjected to braking/traction torque", *Vehicle System Dynamics*, vol. 47, issue 3, 2009, pp. 285-307.
- [21] K. Ramji, "Coupled vertical-lateral dynamics of three-wheeled motor vehicles", Ph.D. Dissertation, Deptt. of Mech. and Indus. Engg., I.I.T., 2004, Roorkee.
- [22] A.H. Wickens. 2003. "Fundamentals of rail vehicle dynamics", Swets & Zeitlinger publishers", 2003, Netherlands.
- [23] C. Esweld, "Modern railway track - Second addition", Delf University of Technology, Mdxccxlii, MRT-Productions, 2001, The Netherlands.